

# 275/P 500A



## HYDRAULIC BOLLARD WITH BUILT-IN PUMP

PILOMAT 275/P 500A automatic bollards are the top line products of the PILOMAT range. Current models are the result of the dedication of more than 40 years in the field of access control, and a twenty-year specialization in bollards. The installation of 275/P 500A bollard is recommended for the management of: pedestrian areas, private parkings, business parkings, private driveways, business driveways, commercial driveways.

Customize your system with the several optionals available to obtain the most effective solution.

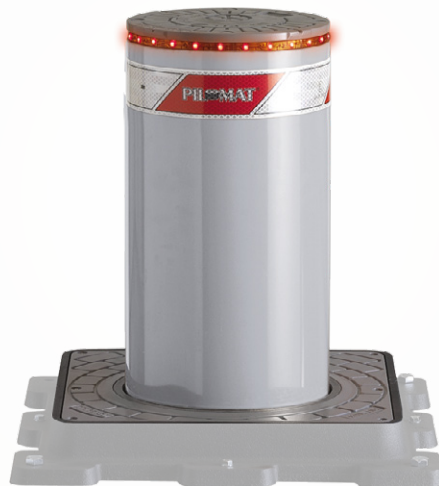

PAG.1/3

**PILOMAT**

100% MADE IN ITALY



PILOMAT s.r.l.  
www.pilomat.com / pilomat@pilomat.com  
Via Zanica 17/p, 24050, Grassobbio (BG) Italy  
Tel. +39.035.29.72.20  
Copyright 2016© Pilomat S.r.l. All rights reserved

275/P 500A\_DATASHEET.16 REVIEW 09/05/2016

## OPTIONAL ITEMS

PILOMAT BOLLARD 275/P 500AIXV - STAINLESS STEEL PAINTED

PILOMAT BOLLARD 275/P 500AIXS - STAINLESS STEEL BRUSHED

PIT IN ALUZINC FOR PILOMAT 275/P 500A - COUNTERFRAME AND BRACKETS  
ONE PIT FOR EACH BOLLARD

CONTROL UNIT FOR PILOMAT 275/P 500A

MULTILED FLASHING LIGHT- 27 LED POINTS

BUZZER ACOUSTIC SIGNAL FOR AUTOMATIC BOLLARDS

REFLECTING ADHESIVE STRIP - WHITE (NO-LOGO)

HEAD WITHOUT LOGO FOR PILOMAT 275/P 500A

PAINTING WITH RAL COLOUR ON REQUEST

BIODEGRADABLE FUCHS OIL FOR HYDRAULIC PUMP

HEATING RESISTANCE FOR PILOMAT BOLLARDS - TRANSFORMER AND THERMOSTAT  
ONE RESISTANCE FOR EACH BOLLARD

RADIO RECEIVER

RADIO TRANSMITTER TWO-CHANNEL

TRAFFIC LIGHT WITH TWO LIGHTS (GREEN-RED)

INDUCTIVE DETECTOR FOR LOOPS

INDUCTIVE LOOP - DIMENSION: 7,60m - 9,60m - 12,60m - LINE: 15m AND 30m

TIMER PROGRAMMER

INDUCTIVE CARD READER

LOCK SELECTOR

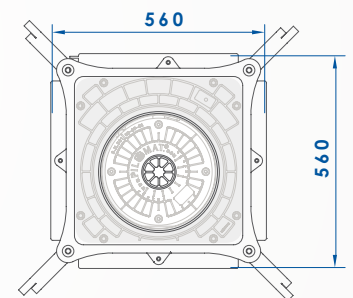
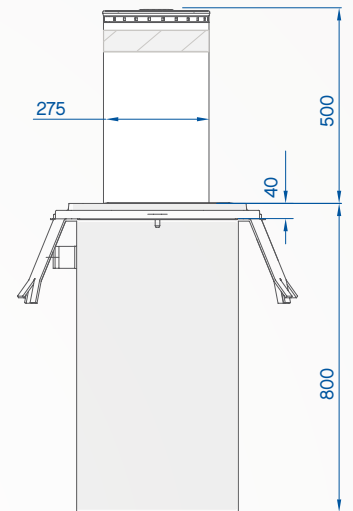

**PILOMAT**

100% MADE IN ITALY



# 275/P 500A



MOVING CYLINDER	NORMAL STEEL FE370
MOVING CYLINDER DIAMETER	275mm
MOVING CYLINDER HEIGHT	500mm
MOVING CYLINDER STAINLESS STEEL THICKNESS	6mm
MOVING CYLINDER STAINLESS STEEL FINISH	ANTI-CORROSION TREATMENT - STANDARD PAINTING GREY ANTHRACITE OR BRUSHED
OTHER MOVING CYLINDER FINISH	RIBS ON CYLINDER'S SURFACE
REFLECTING ADHESIVE STRIP	YES - HEIGHT 55mm
RISING SPEED	15cm/s
LOWERING SPEED	25cm/s
MANUAL EMERGENCY LOWERING	YES (ALSO FOR VERSION WITH AUTOMATIC LOWERING IF POWER FAILED)
SAFETY REVERSAL PRESSURE SWITCH	YES
CONNECTION LINE TO CONTROL UNIT	STANDARD 10m (MAX. LENGTH 80m - WITH HEATING RESISTANCE MAX. 50m)
VOLTAGE FOR CONTROL UNIT	230Vac (+/- 10%) 50/60Hz
HYDRAULIC PUMP	BUILT-IN THE BOLLARD
PROTECTION CLASS	IP67
TYPE OF USE	INTENSIVE - LIFE AVERAGE 3.000.000 MOVEMENTS - 2000 MOVEMENTS/DAY
IMPACT RESISTANCE (WITHOUT DEFORMATION)	40.000 J
BREAKOUT RESISTANCE	250.000 J
OPERATING TEMPERATURE	-40 °C +70 °C (FOR LOW TEMPERATURES SEE HEATING RESISTANCE)

